



## Suikerpalm 28, Suikerpalm

**US\$ 196,830 Fixed price**

Buyers costs, excluding measure costs US\$ 1,285,-.

Suikerpalm

## Real Estate information

Neighborhood	Suikerpalm
Address	Suikerpalm 28
Freehold Land	
New construction	
Total ground area	7,847 / 729 sq.ft./m2

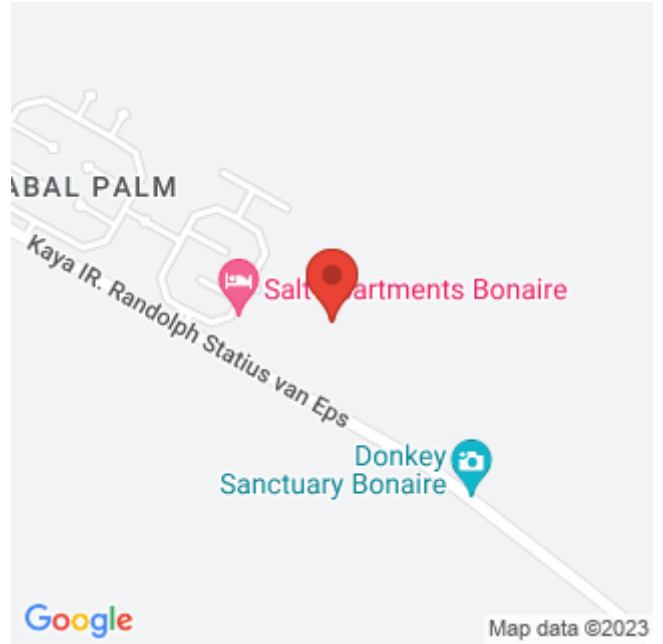

Ground tax (annually): 0.345% of the value (1st residence), or Property tax (annually): 0.91% of the value (2nd residence). Buyers Costs consist of (one-off): 5% transfer tax, approx. 2% notary costs and costs of Land Registry at the office of Kadaster depending on purchase price.

Registered at the Land Registry Office Kadaster as division 4, section H, number 839.



## Features

Lot 28 is located at the outer ring of the Suikerpalm allotment. The location of this lot is adjacent to an undeveloped zone between La Palma and the Donkey Sanctuary. With only a 5 minute drive to the Sorobon area to the east and only a 2 minute drive to the nearest beach 'Bachelor Beach' to the west this allotment plan is located in between the most beautiful coastal areas of Bonaire. The center of Kralendijk is only a 10-minute drive away.

At Suikerpalm, the roads are paved and utilities installed underground. The location offers not only tranquility and serenity, but also easy access to local amenities, restaurants, and the unique culture of Bonaire. Whether you're a fan of water sports, diving, or simply want to relax on the beautiful beaches, this building plot brings island life within reach.

- no building obligation,
- close to popular beaches and the Caribbean Sea,
- build your own dream home,
- water and electricity connections available and roads are paved,
- accessibility: good, only 10 minutes to the center of Kralendijk,
- location: adjacent to an undeveloped zone between Suikerpalm and the Donkey Sanctuary.

[Click here for all available plots at Suikerpalm](#)

Association of owners of roads and facilities Suikerpalm - Annual contribution per plot is USD 200.00.



## Technical specifications

- link to zoning description: [zoning "Woongebied II"](#)
- download special conditions: [further special terms and conditions for Suikerpalm.pdf](#)

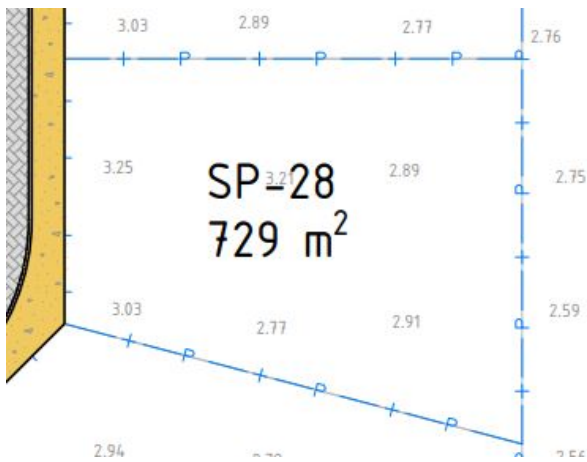

- maximum building percentage (%): 40
- maximum building height (m): 6
- maximum gutter height (m): 4

