



Suikerpalm 47, Suikerpalm

US\$ 129,500 Asking price **SALE PENDING**

Buyers Costs

Suikerpalm

Real Estate information

Neighborhood	Suikerpalm
Address	Suikerpalm 47
Freehold Land	
New construction	
Total ground area	5,188 / 482 sq.ft./m2



Ground tax (annually): 0.345% of the value (1st residence), or Property tax (annually): 0.91% of the value (2nd residence). Buyers Costs consist of (one-off): 5% transfer tax, approx. 1.5% notary costs and costs of Land Registry at the office of Kadaster depending on purchase price.

Registered at the Land Registry Office Kadaster as division 4, section H, number 863.



Description

Lot 47 is located at the inner ring of the northern part of the Suikerpalm allotment. With only a 5 minute drive to the Sorobon area to the east and only a 2 minute drive to the nearest beach 'Bachelor Beach' to the west. It is located in the middle of the most beautiful coastal areas of Bonaire. The center of Kralendijk is only a 10-minute drive away.

At Suikerpalm, the roads are paved and utilities are installed underground at your convenience. Everything is prepared for you to start building your dream home on Bonaire. As part of the zoning plan for Bonaire, Suikerpalm is one of the last allotment projects where you can buy a plot. As an extra bonus, there is no construction obligation on Suikerpalm, so you retain all the freedom.

Nice to know; The Suikerpalm plant species is also known as *Arengo saccharifera*, the spike palm, which provides the spikes and Javanese sugar.

- spacious inner ring plot,
- no building obligation,
- close to popular beaches and the Caribbean Sea,
- build your own dream home,
- water and electricity connections available and roads will be paved,
- accessibility: good, only 10 minutes to the center of Kralendijk,
- location: located near the main road Kaya Status of Eps which continues to Sorobon Beach, next to allotment plan La Palma.

[Click here for all available plots at Suikerpalm](#)

Association of owners of roads and facilities Suikerpalm - Annual contribution per plot is USD 200.00.



Technical specifications

- link to zoning description: [zoning "Woongebied II"](#)
- download special conditions: [further special terms and conditions for Suikerpalm.pdf](#)

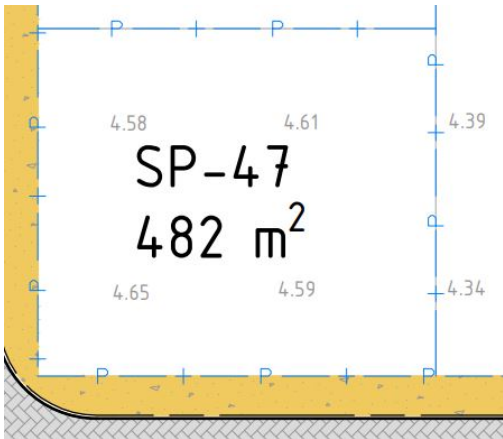

- maximum building percentage (%): 40
- maximum building height (m): 6
- maximum gutter height (m): 4

